

Item 4.3 ( 1 : 5 )

SECTION BR-BR  
SCALE 1 : 1

Note: Material-Hot dip galvanized

THIS PLAN AND ALL COPIES ARE RELEASED TO THE PUBLIC BY CREATOR: <b>CARNETIC</b> <small>CLEAN POWER IN MOTION</small> THE SOLE PROPERTY OF CARNETIC BY CREATOR STEINAR VIGDEL KOLNES UNDER THE CREATIVE COMMON (CC BY) LICENCE.	Designed by Edgar	Checked by	Approved by	Date	Material	Date 25-Sep-24	Item 40.3	First Angle Projection
	All dimensions are in millimeter unless otherwise specified				Description Wing Hub1		Part name CWT-01-40.3	Scale 1 : 5

PARTS LIST			
ITEM	QTY	PART NUMBER	DESCRIPTION
40.1	1	CWT-01-40.1	Wing Hub 2
40.2	1	CWT-01-40.2	Pole Extension Ø76.2x4 x L909.961
40.3	1	CWT-01-40.3	Wing Hub1
40.4	9	CWT-01-40.4	Wing holder Gusset Plate 75x75x106

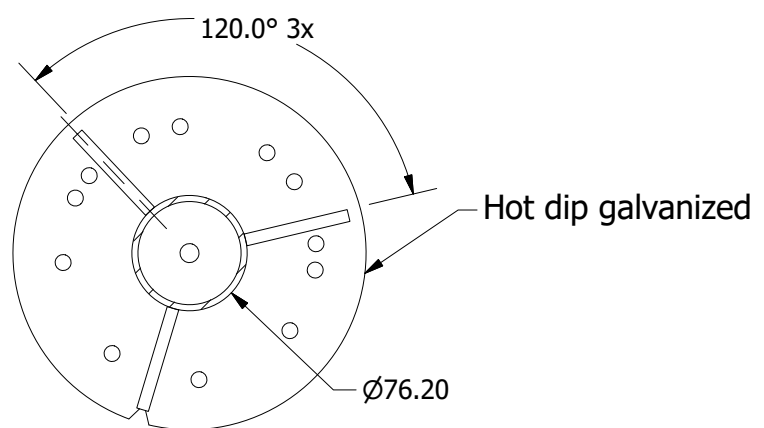
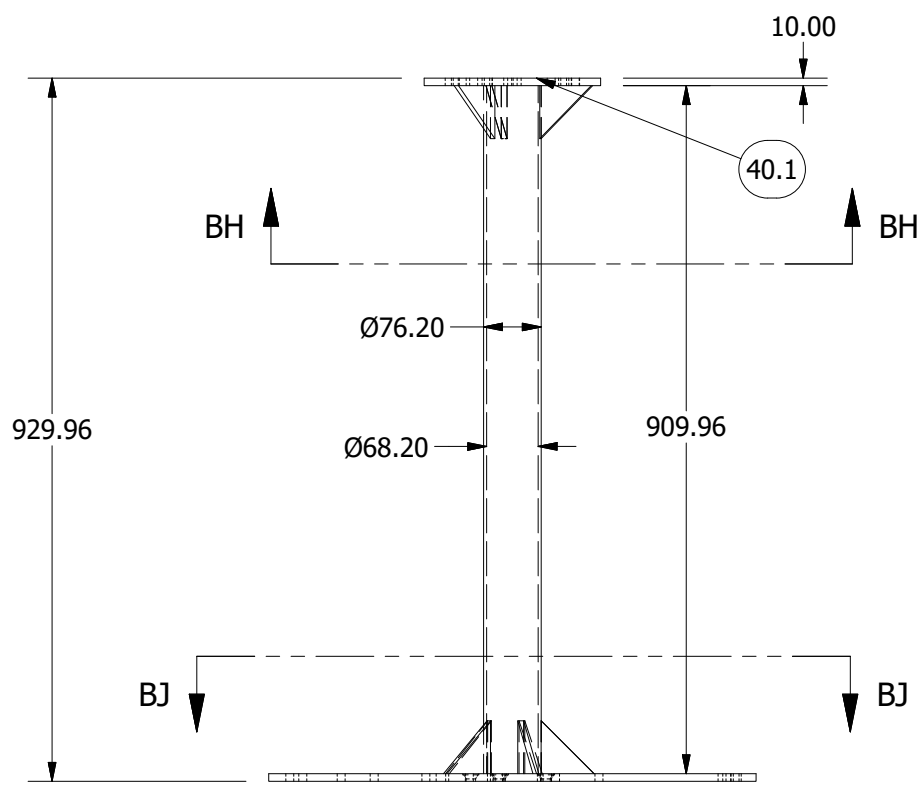

SECTION BH-BH  
SCALE 1 : 5

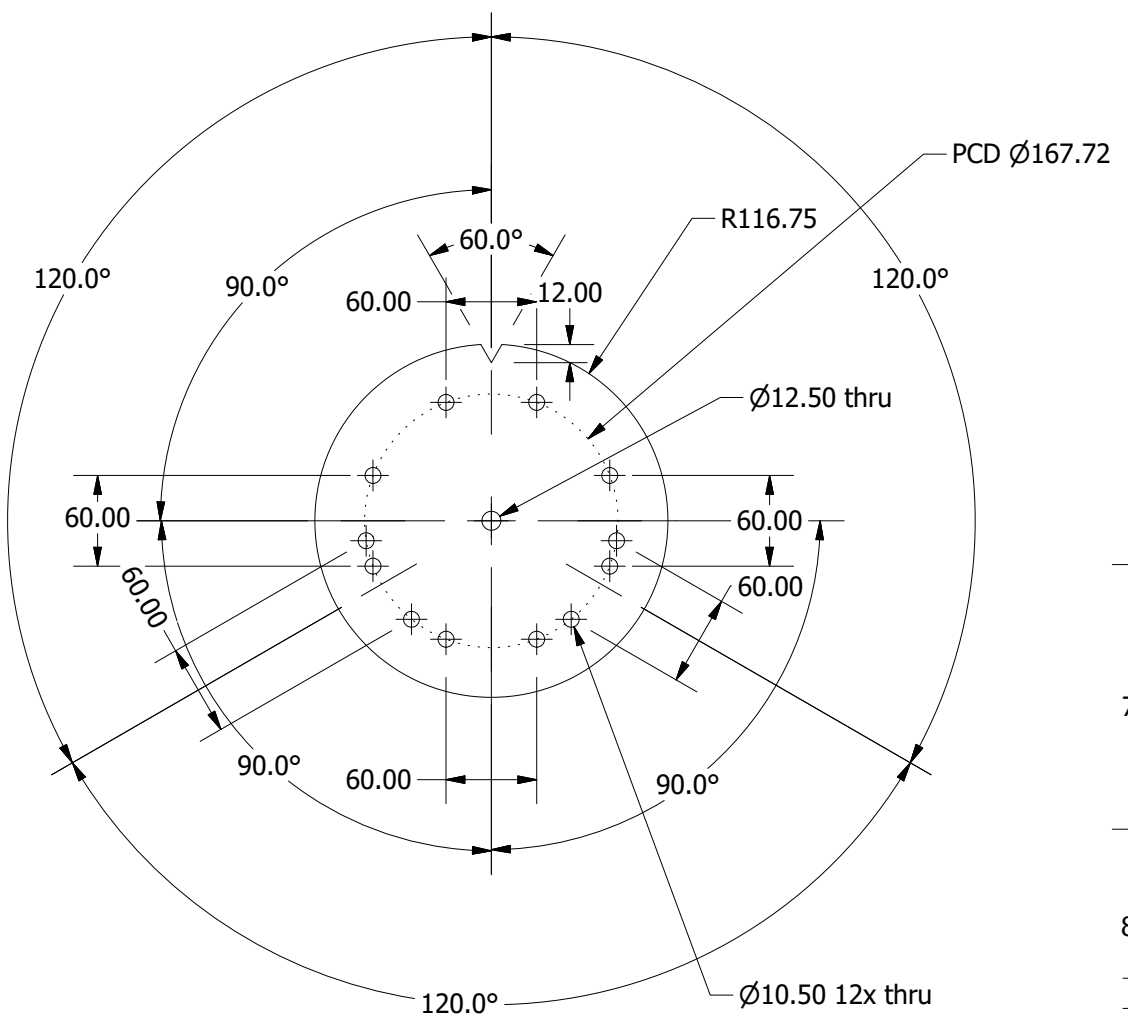

Item 40.1  
SCALE 1 : 5

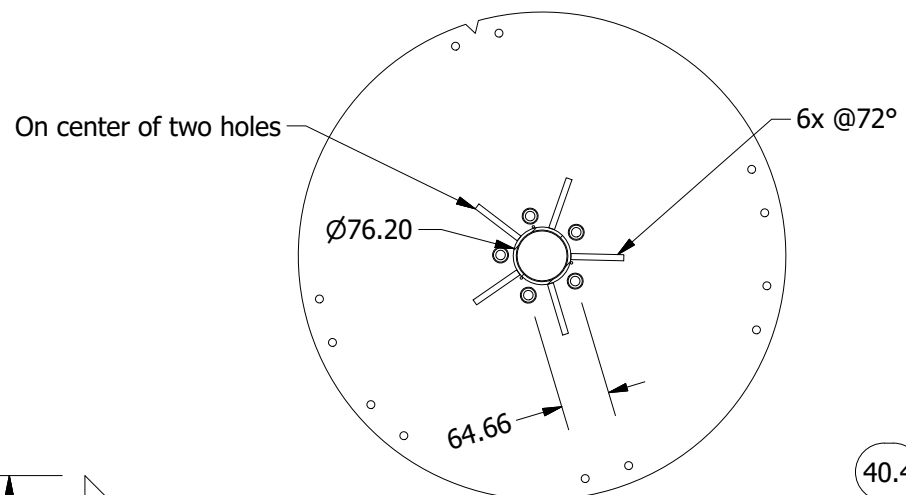

SECTION BJ-BJ  
SCALE 1 : 10

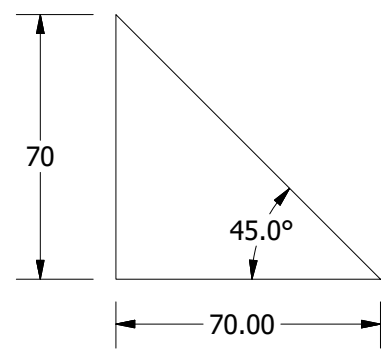

8.00

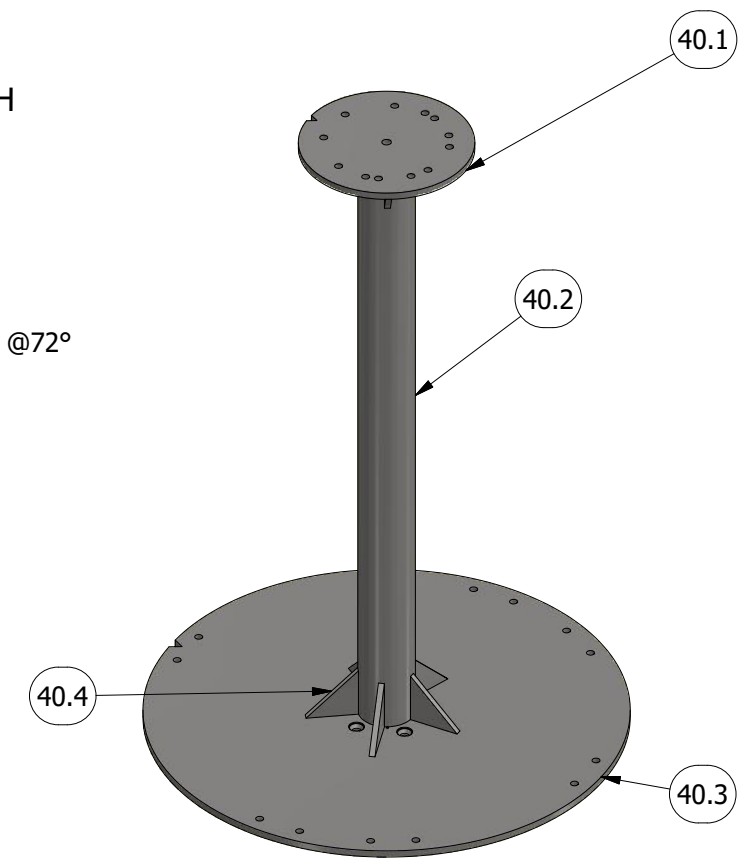

THIS PLAN AND ALL COPIES ARE RELEASED TO THE PUBLIC BY CREATOR: <b>CARNETIC</b> CLEAN POWER IN MOTION THE SOLE PROPERTY OF CARNETIC BY CREATOR STEINAR VIGDEL KOLNES UNDER THE CREATIVE COMMON (CC BY) LICENCE.	Designed by Edgar	Checked by	Approved by	Date	Material	Date 25-Sep-24	Item 40	First Angle Projection
	All dimensions are in millimeter unless otherwise specified				Description Wing Hub		Part name CWT-01-40	Scale 1 : 10